

Switch-Pak™ AX13

with Compact Level Controller



Application

The general purpose level switch package provides high or low liquid level detection with one 16A compact relay controller for pump or valve shut off. The optional flash alarm brings attention to alarm conditions. Available in three level sensor technologies, choose the sensor type based upon your application media. This PP or PVDF level switch package is selected for bulk storage, IBC or drum, and neutralization tank applications, requiring detection and control.



Features

- Fail-safe relay shut off of pumps or valves with adjustable time delay
- Offered in three sensor technologies for broad application coverage
- Rugged polypropylene or PVDF construction for use with corrosive liquids
- Easy setup with LED indicators for sensor, power and relay status
- Optional strobe brings immediate attention to level alarm conditions
- Polypropylene enclosure rated NEMA 4X with swivel base for conduit alignment
- Invert switch changes relay state from NO to NC without rewiring



AU13-4213 Shown

Key Benefits

- Complete solution to shut off a pump or close a valve to prevent overflows or run dry - just add power
- Available in three sensor technologies and two materials for all types of liquid media

Sensor Technologies



LU10

SWITCH-TEK™

Ultrasonic Level Switch

Broadly applied in chemicals and light weight oils



SWITCH-TEK™

Vibration Level Switch

Applied in wastewater with light coating or scaling



LV10

SWITCH-TEK™

Vertical Buoyancy Level Switch

Applied in clean water and

Switch-Pak™ AX13

with Compact Level Controller



Specifications

Length:	6" to 10' (15cm to 3m)
Accuracy:	± 1mm in water
Repeatability:	± 0.5mm in water
Orientation:	± 20° vertical
Switch points:	1 (factory set)
Supply voltage:	120 / 240 VAC @ 50-60 Hz.
LED indication:	Sensor, power & relay
Consumption:	0.25A maximum
Strobe type:	-X22X: N/A -X21X: Xenon tube
Strobe flash:	-X22X: N/A -X21X: 1 per second
Contact type:	(1) SPDT relay
Contact rating:	250 VAC @ 16A
Contact output:	Selectable NO / NC
Contact delay:	0.15 - 60 seconds
Process temp.:	F: -40° to 176° C: -40° to 80°
Ambient temp.:	F: -40° to 140° C: -40° to 60°
Installed height:	_21_: 6.5" (16.5cm) _22_: 4.9" (12.4cm)
Pressure:	AV13: 25 psi (1.7 bar) AU13 / AZ13: 150 psi (10 bar)
Enclosure rating:	NEMA 4X (IP65)
Encl. material:	-X21X: PP, UL94VO & PC -X22X: PP, UL94VO
Conduit entrance:	1/2" NPT
Wetted material:	AV13-42XX: PP AV13-52XX: PVDF AU13-42XX: PP AU13-52XX: PVDF & PFA AZ13-42XX: PP & Ryton®
Process mount:	-X2X3: 2" NPT -X2X7: 1-1/2" G
Classification:	General purpose
Compliance:	CE

Dimensions

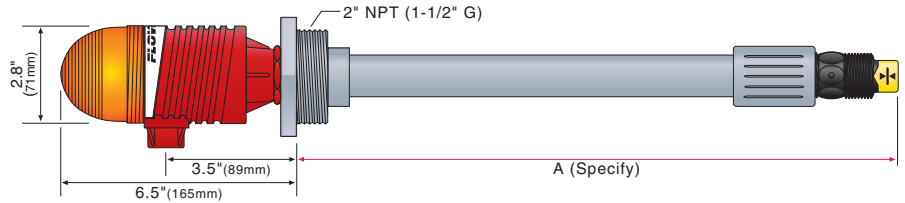

Fittings

For optimum performance, install Switch-Pak™ using the below recommended or direct equivalent fittings.

	P/N	DESCRIPTION
	LM52-2400	3" NPT x 2" NPT, PVC, schedule 40
	LM52-2800	3" NPT x 2" NPT, PVC, schedule 80
	LM52-3800	4" NPT x 2" NPT, PVC, schedule 80
	LM52-2410	3" socket x 2" NPT, PVC, schedule 40
	LM52-3410	4" socket x 2" NPT, PVC, schedule 40
	LM52-2810	3" socket x 2" NPT, PVC, schedule 80
	LM52-3810	4" socket x 2" NPT, PVC, schedule 80
	LM52-2890	2" NPT bulkhead, PVC
	LM52-2850	2" ANSI x 2" NPT, PVC, schedule 80
	LM50-1001	2" NPT side mount bracket, PP

Ordering

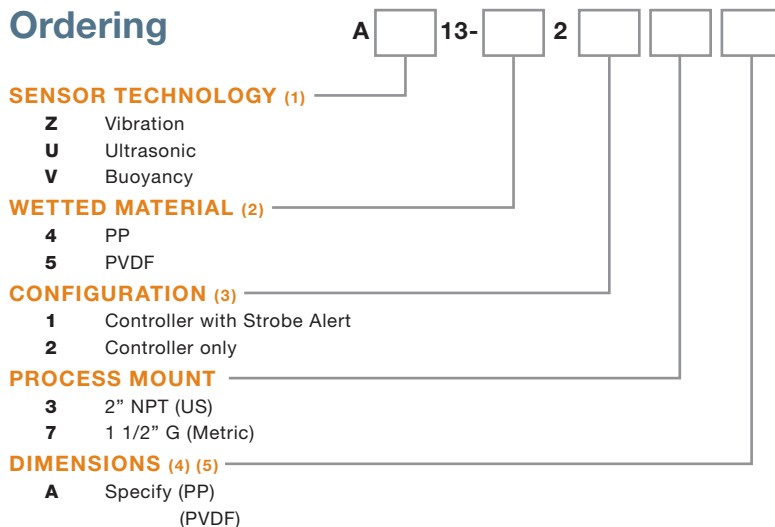

NOTES

- 1) Select the best level sensor technology based upon your application.
- 2) Vibration is only available in PP material with a Ryton® sensor body.
- 3) CE compliance is only available in the non-strobe configuration.
- 4) Specify the A-dimension at the end of the part number (ie: AV13-4223-17"). The dimension may be specified in 1/2" (1.3cm) increments from 6" to 10' (15cm to 3m).
- 5) To calculate the length adder, round up the A-dimension to the next foot (30cm), multiply it by the selected material, and add that sum to the price. For PP, add \$10 per foot (30cm). For PVDF, add \$50 per foot (30cm).